

SETUP SHEET for the Team Associated RC10B4

Driver Joe Nolasco
 Track / City Current Base Setup
 Event _____ Date 12-30-2007

FRONT SHOCK MOUNTING & CAMBER LINK

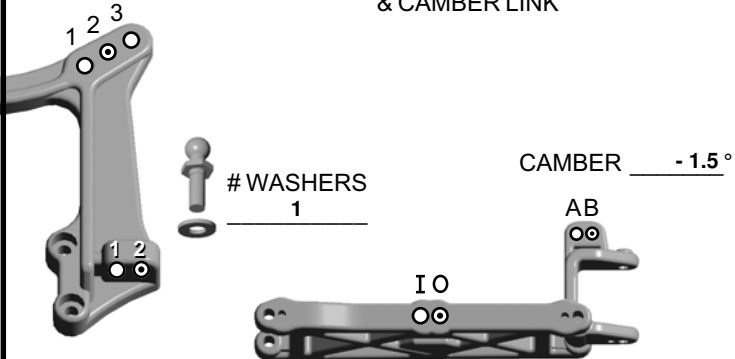

RIDE HEIGHT A-arms Level

CAMBER -1.5°

WASHERS 1

TOE-IN (+) / OUT (-) 0°

BUMP STEER SPACER 1

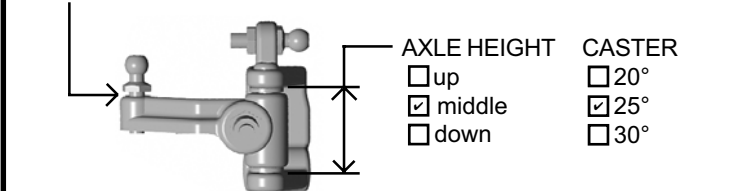

AXLE HEIGHT up middle down

CASTER 20° 25° 30°

STEERING BLOCK trailing inline

FRONT SHOCKS

OIL 35 wt

SPRING (color) Brown PISTON # 1

SHAFT unobtainium STD # LIMITERS See note

FRONT TIRES & WHEELS

FRONT TIRES Pro-Line M3 Widebody 4 Ribs

INSERTS Stock WHEELS AE Stock

TRACTION COMPOUND _____

REAR SHOCK MOUNTING & CAMBER LINK

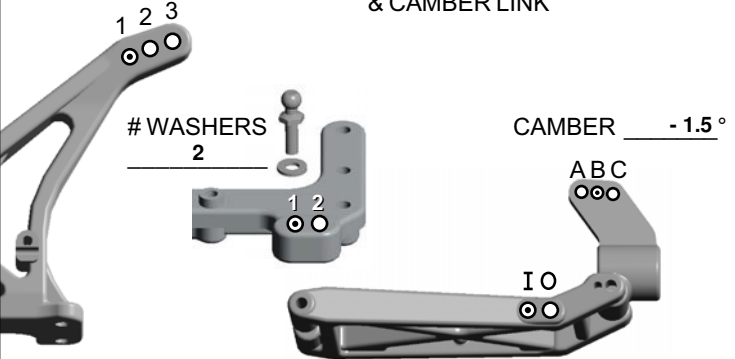

RIDE HEIGHT Dog Bones Level

CAMBER -1.5°

WASHERS 2

ANTI-SQUAT 0° 1° 2° 3°

ANTI-ROLL BAR none black (soft) silver (med) gold (heavy)

WHEELBASE long medium short

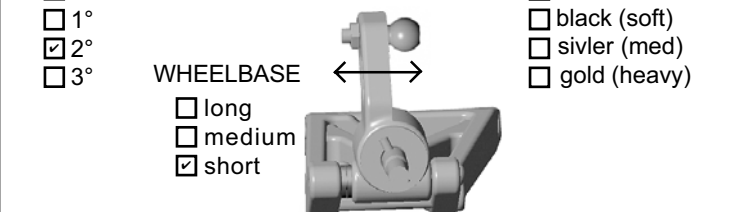

REAR SHOCKS

OIL 30 wt

SPRING (color) Green PISTON # 1

SHAFT unobtainium STD # LIMITERS .030

REAR TIRES & WHEELS

REAR TIRES Pro-Line M3 Holeshots

INSERTS Stock WHEELS AE Stock

RADIO/BATTERIES

RADIO M8 SERVO Air 357

ESC GT7

DRAG BRAKE 2 INIT BRAKE Full

BATTERY PLACEMENT front rear

BATTERIES Pro-Match

MOTOR

MOTOR & WIND Reedy KR 11x2

BRUSHES 767 (I think...)

SPRING Stk

PINION / SPUR 21 / 81

OTHER

BODY Stock

WING Stock

WING ANGLE 0° 3° 6°

CHASSIS Plastic

CONDITIONS

smooth sandy

bumpy soft dirt

low traction grass

med traction blue groove

high traction clay

wet dusty

dry other

COMMENTS

Unscrew front shock bottoms two full turns and use zero limiters under the piston